

AVOIDED GREENHOUSE GAS EMISSIONS FROM US PULP AND PAPER INDUSTRY BIOMASS-DERIVED ELECTRICITY

NCASI WHITE PAPER
WP 24-05
MAY 2024

Authored by
Dr. Barry Malmberg, NCASI
Sheridan, Wyoming

For more information about this report, contact:

Barry Malmberg, NCASI
Principal Research Scientist
PO Box 271, Sheridan, WY 82801 US
(541) 249-3986
bmalmberg@ncasi.org

Kirsten Vice, NCASI
Vice President, Sustainability & Climate Program and Canadian Operations
2000 McGill College Avenue, 6th Floor Montréal, QC H3A 3H3 Canada
(514) 907-3145
kvice@ncasi.org

To request printed copies of this white paper, contact NCASI at publications@ncasi.org or (352) 244-0900.

Cite this report as:

NCASI. 2024. *Avoided Greenhouse Gas Emissions from US Pulp and Paper Industry Biomass-Derived Electricity*. White Paper (WP-24-05). Cary, NC: National Council for Air and Stream Improvement, Inc.

©2024 by the National Council for Air and Stream Improvement, Inc.

About this report:

The greenhouse gas (GHG) emission intensity characteristics of electricity generated by the US pulp and paper sector are presented in this report. The US pulp and paper sector generates 95% of its on-site electricity via combined heat and power (CHP). CHP systems, sometimes referred to as cogeneration units, generate both steam and electricity; therefore, it is necessary to allocate GHG emission impacts, as well as avoided emissions, from this sector via GHG allocation approaches. In this report, all major GHG allocation approaches are reviewed and applied to the US pulp and paper sector to generate allocation fractions for heat and electricity. Fenceline (only considering emissions generated or released by the facility) GHG emission intensities for the US pulp and paper sector, excluding consideration of avoided emissions, ranged from 82 to 316 g CO₂e/kWh, depending on the allocation approach used. Incorporating consideration of avoided life cycle GHG emissions from biomass utilization for energy generation within the US pulp and paper sector results in large negative emission intensities for industry-generated electricity. When incorporating avoided emissions and considering GHG allocation approaches to allocate avoided emissions to steam and electricity generation, life cycle GHG emission intensities from industry-generated electricity range from (709) to (2814) g CO₂e/kWh for electricity derived from spent liquor solids and range from (482) to (1812) g CO₂e/kWh for electricity derived from all other biomass sources¹. The functions of the kraft recovery system that utilize black liquor, a by-product of the kraft pulping process, not only generate energy but recover pulping chemicals and manage black liquor solids and thus confer additional avoided GHG emissions when alternative use scenarios are considered compared to other biomass sources. Even when a portion of the electricity used in a pulp and paper mill is derived from supplemental fossil fuels, as is typical for the US pulp and paper sector, the large negative (i.e., avoided) emissions from utilizing biomass residuals more than offset the life cycle GHG emission amounts from use of fossil fuels, resulting in negative emissions for industry-generated electricity.

About NCASI:

NCASI (National Council for Air and Stream Improvement, Inc.) is a non-profit environmental research organization that seeks to create credible scientific information to address the environmental information needs of the forest products industry in North America. NCASI conducts surveys, performs field measurements, undertakes scientific research, and sponsors research by universities and others to document the environmental performance of industry facility operations and forest management, and to gain insight into opportunities for further improvement in meeting sustainability goals.

¹ Note that the use of parentheses in this report indicates negative emissions (i.e., avoided emissions).

AVOIDED GREENHOUSE GAS EMISSIONS FROM US PULP AND PAPER INDUSTRY BIOMASS-DERIVED ELECTRICITY

EXECUTIVE SUMMARY

Although the US pulp and paper sector is the largest contributor to biomass-derived electricity in the US, no life cycle study on the greenhouse gas (GHG) emission characteristics of biomass-derived electricity has been conducted for the sector. The US pulp and paper sector generates 95% of its on-site electricity needs via combined heat and power (CHP). CHP systems, sometimes referred to as cogeneration units, generate both steam and electricity; therefore, it is necessary to allocate the GHG emission impacts, as well as avoided emissions, from this sector via GHG allocation approaches. In this report, all major GHG allocation approaches are reviewed and applied to the US pulp and paper sector to generate allocation fractions for heat and electricity. Fenceline (only considering emissions generated or released by the facility) GHG emission intensities for the US pulp and paper sector, excluding consideration of avoided emissions, ranged from 82 to 316 g CO₂e/kWh, depending on the allocation approach used. In a series of studies on the GHG benefits of biomass energy consumption in the US forest products sector, National Council for Air and Stream Improvement, Inc. (NCASI) provided information on the avoided life cycle GHG emission savings from biomass utilization for energy generation in the sector (NCASI 2011; Gaudreault et al. 2012; NCASI 2013 (revised 2014); NCASI 2017). Incorporating avoided emissions and considering GHG allocation approaches to allocate avoided emissions to steam and electricity generation, life cycle GHG emission intensities from industry-generated electricity range from (709) to (2814) g CO₂e/kWh for electricity derived from spent liquor solids and range from (482) to (1812) g CO₂e/kWh for electricity derived from all other biomass sources. The functions of the kraft recovery system that utilize black liquor, a by-product of the kraft pulping process, not only generate energy but recover pulping chemicals and manage black liquor solids and thus confer additional avoided GHG emissions when alternative use scenarios are considered compared to other biomass sources. Even when a portion of the on-site electricity generation at a pulp and paper mill is derived from supplemental fossil fuels, as is typical for the US pulp and paper sector, the large negative (i.e., avoided) emissions from utilizing biomass residuals more than offset the life cycle GHG emission amounts from the use of fossil fuels, resulting in negative emissions for industry-generated electricity.

KEYWORDS

greenhouse gas emissions, avoided greenhouse gas emissions, pulp and paper, electricity generation, biomass

Table of Contents

1.0 Introduction	8
2.0 Summary	9
3.0 Previous Studies	10
4.0 Biomass Fuel Types used for Electricity Generation with the US Pulp and Paper Sector.....	13
4.1 Spent Liquor Solids.....	14
4.2 Manufacturing Biomass Residuals	14
5.0 Combined Heat and Power	16
6.0 Allocation of Life Cycle GHG Emissions to Steam and Electricity	19
7.0 Conclusions	22
References	23
Appendix A: Avoided GHG Emissions from the Use of CHP in the US Pulp and Paper Industry	25
Calculation Procedure	25
Energy Used in Lime Kilns, Total Reduced Sulfur Incinerators, and Gas Turbines	26
Power Production from Steam Turbines	28
Gas Turbines	29
Avoided GHG Emissions from CHP.....	29
Scale-Up to Total US Production.....	30
Appendix A References	31
Appendix B: CHP GHG Allocation Approaches for the Pulp and Paper Industry	32
Introduction	32
Summary of Approaches.....	32
Allocation Based on Energy Content of Products	33
The Simplified Efficiency Method	33
Work Potential Method	35
Allocation Based on Economic Value of Products	36
Allocation Based on Incremental Fuel Consumption for Electrical Production.....	36
Allocation Based on Incremental Fuel Consumption for Steam Production	37
Appendix B References	39

Figures

Figure 1. Electricity Derived from Renewables and Non-renewable Energy Sources in the US in 2018	8
Figure 2. Electricity Derived from Renewable Energy Sources in the US in 2018.....	9
Figure 3. Life Cycle GHG Emission Estimates from Bio-Based Electricity Generation	11
Figure 4. Life Cycle GHG Emission Estimates from Electricity Generation and Storage Technologies and Some Technologies Integrated with Carbon Capture and Storage	12
Figure 5. Distribution of Life Cycle GHG Emission Estimates from Electricity Generation by Feedstock Categories ..	12
Figure 6. Point Estimates of Life Cycle GHG Emission Estimates from Electricity Generation by Feedstock Categories	13
Figure 7. Life Cycle GHG Emission Estimates for Woody Biomass by US State and by Life Cycle Stage.....	13
Figure 8. Energy Fractions for US Forest Products Industry’s (Both Pulp and Paper and Wood Products Sectors) Biomass Residuals Other Than Spent Liquor Solids.....	15
Figure 9. Energy Fractions for the US Pulp and Paper Sector’s Biomass Residuals Other Than Spent Liquor Solids ..	15
Figure 10. Typical Steam and Power Balance at a Kraft Mill	17
Figure 11. Simplified Block Diagram of a Chemical Pulp Mill Combined Heat and Power System.....	18
Figure 12. Fuels Used in US Pulp and Paper Sector Cogeneration Systems in 2018	21
Figure A1. Schematic Used to Translate EHS Data to Steam and Electricity Generation in Pulp and Paper CHP Systems.....	26
Figure A2. Steam and Electricity Generation in a CHP System	29
Figure A3. Separate Generation of Steam and Electricity	29
Figure B1. Variation of Fractional Allocation Amounts by Method.....	33

Tables

Table 1. Life Cycle Emission Factors for Electricity Generation from Previous Studies or Meta-analyses	10
Table 2. US Forest Products Industry Installed CHP Capacity.....	16
Table 3. The US Forest Products Industry Electricity Generation Profile	17
Table 4. Difference in Total Life Cycle GHG Emissions Over 100 Years	18
Table 5. Life Cycle GHG Mitigation Benefits for Biomass Residuals Energy Systems in the US Forest Products Sector	19
Table 6. US Pulp and Paper Sector GHG Allocation Fractions for CHP Systems by Method	20
Table 7. Life Cycle GHG Emission Characteristics of Biomass-derived Electricity Considering Avoided Emissions for the US Pulp and Paper Sector	20
Table 8. Life Cycle GHG Emission Characteristics of Fossil Fuel Derived Electricity	21
Table 9. GHG Emission Characteristics of US Pulp and Paper Sector Produced Electricity	22
Table A1. US Pulp and Paper Industry GHG Emissions from Use of CHP Technology in 2018 Compared to the Separate Generation of Heat and Power	25

Table A2. Energy Consumption from Lime Kilns, TRS Incinerators, and Gas Turbines	26
Table A3. 2018 Fuels Used for Cogeneration	27
Table A4. Boiler Thermal Efficiencies Based on Fuel Type	27
Table A5. Steam and Feedwater Conditions Used in CHP Analysis	28
Table A6. Soot-blowing Steam Requirements Based on Fuel Type	28
Table B1. Variation of Fractional Allocation Amounts by Method	32
Table B2. Literature with Published Thermal Efficiencies for Fuel Type Common in the Pulp and Paper Sector	34
Table B3. Carnot Efficiencies for the Work Potential Method	35

AVOIDED GREENHOUSE GAS EMISSIONS FROM US PULP AND PAPER INDUSTRY BIOMASS-DERIVED ELECTRICITY

1.0 Introduction

In 2018, 4.181 trillion kWh of electricity was generated in the United States². Of this amount, 0.7068 trillion kWh of electricity, or 17% of total generation, was generated from renewable sources. Of the 17% of total generation from renewables, biomass-based electricity generation represented 61.83 billion kWh of electricity generation, or 2% of total generation (Figure 1). The US Environmental Protection Agency’s (EPA) emission and generation resource integrated database (eGRID)³ is a comprehensive source of data on electricity generation in the US. eGRID classifies electricity generation from hydro, biomass, wind, solar, and geothermal energy sources as renewable electricity generation.

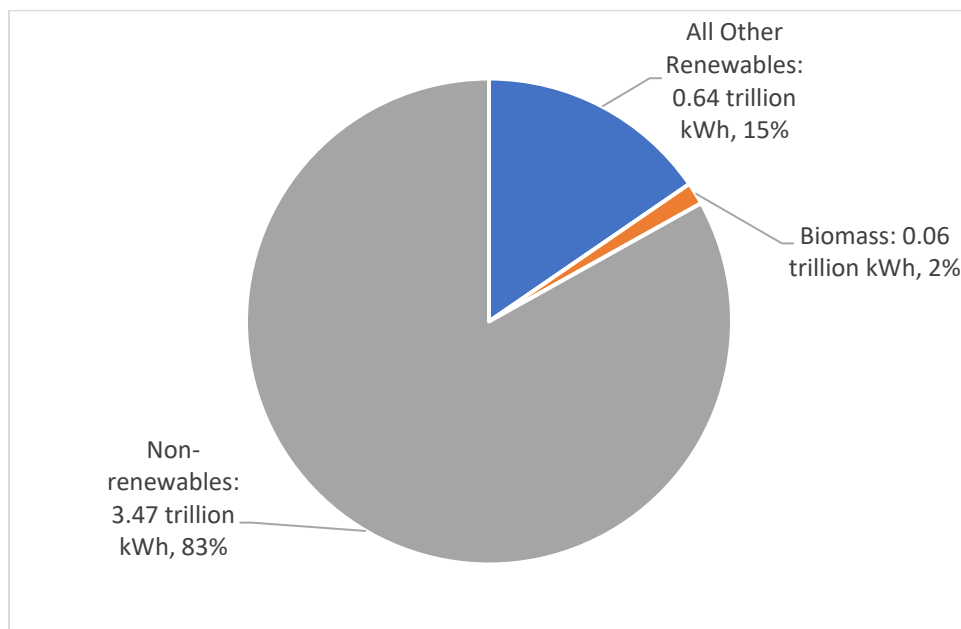

Figure 1. Electricity Derived from Renewables and Non-renewable Energy Sources in the US in 2018

In 2018, biomass-derived electricity represented 8.7% of total generation from renewable sources. Biomass-derived electricity from the US pulp and paper sector represented nearly half of the electricity generated nationally from biomass energy sources and was 30.79 billion kWh in 2018 (Figure 2)⁴.

² US Energy Information Administration (EIA) Electricity Overview.

https://www.eia.gov/totalenergy/data/monthly/pdf/sec7_3.pdf

³ US EPA Emission & Generation Resource Integrated Database (eGRID). <https://www.epa.gov/egrid>

⁴ US EIA MECS. "Table 11.3 Electricity: Components of Onsite Generation, 2018."

https://www.eia.gov/consumption/manufacturing/data/2018/pdf/Table11_3.pdf

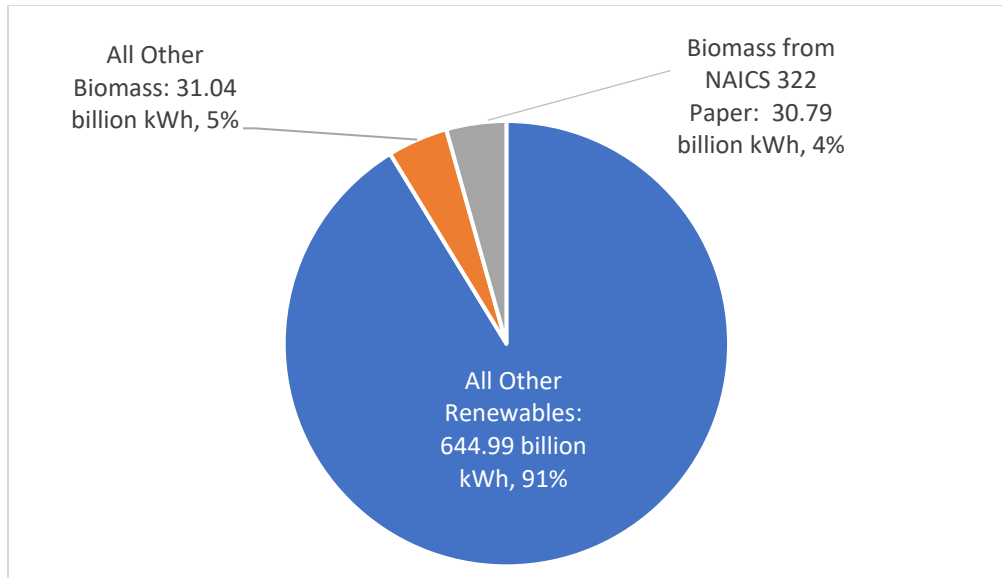

Figure 2. Electricity Derived from Renewable Energy Sources in the US in 2018

Although the US pulp and paper sector is the largest contributor to biomass-derived electricity in the US, no comprehensive study on the greenhouse gas (GHG) emission characteristics of biomass-derived electricity has been conducted for the sector. Previous work on characterizing life cycle GHG emissions of bio-based electricity has been for systems designed for the exclusive generation of electricity. (Reviews of the state of the exclusive generation of bio-based electricity can be found in EPRI (2013); NCASI (2014); and NREL (2021).) The pulp and paper sector generates steam *and* electricity, predominately through efficient combined heat and power (CHP) systems, and therefore, GHG burdens and avoided emissions must be allocated between the steam and electricity co-products. The goal of this white paper is to quantify life cycle GHG emissions from industry-generated electricity, including avoided emissions, from the use of biomass residual fuels. The GHG characteristics of pulp and paper mill electricity generation when on-site use of fossil fuels supplements a portion of the heat and power needs at the mill, which is a typical scenario at US pulp and paper facilities, is also estimated.

2.0 Summary

The US pulp and paper sector generated 95% of its total on-site generation of electricity via CHP in 2018. Because CHP systems generate steam and electricity, it is necessary to allocate the GHG emission impacts, as well as avoided emissions, via GHG allocation approaches. An overview of the most prominent allocation approaches applied to the pulp and paper sector is provided in Appendix A. Fenceline GHG emission intensities (i.e., only considering emissions generated or released by the facility) for the US pulp and paper sector, excluding consideration of avoided emissions, ranged from 82 to 316 g CO₂e/kWh, depending on the allocation approach used. In a series of studies on the GHG benefits of biomass-derived energy consumption in the US forest products industry, National Council for Air and Stream Improvement, Inc. (NCASI) provided information on the avoided life cycle GHG emissions from biomass utilization for energy generation in the sector (NCASI 2011; Gaudreault et al. 2012; NCASI 2013 (revised 2014); NCASI 2017). Incorporating avoided emissions and using a spectrum of major GHG allocation approaches to allocate avoided emissions to steam and electricity generation, life cycle GHG emission intensities from industry-generated electricity range from (709) to (2814) g CO₂e/kWh for electricity derived from spent liquor solids and from (482) to (1812) g CO₂e/kWh for electricity derived

from all other biomass sources⁵, depending on the allocation approach used. Even when a portion of the electricity used in a pulp and paper mill is derived from supplemental fossil fuels, as is typical for the US pulp and paper sector, negative emissions for industry-generated electricity are calculated because the large negative (i.e., avoided) emissions from utilizing biomass residuals more than offset the life cycle GHG emission amounts from using fossil fuels.

3.0 Previous Studies

Life cycle GHG emission intensity for stand-alone biomass-derived electricity generation, excluding consideration of avoided emissions, ranges from 15 to 130 g CO₂e/kWh from previous work and from several meta-analyses (compilations of life cycle assessment studies).

Table 1. Life Cycle Emission Factors for Electricity Generation from Previous Studies or Meta-analyses

Fuel	Emission Intensity (g CO ₂ e/kWh)	Emission Intensity Type	Source
Biomass	42	Median	IPCC (2011)
Mill Residue	15	Median, harmonized	EPRI (2013)
Biomass	8.5 to 130	Range	Turconi et al. (2013)
Biomass	52	Median, harmonized	NREL (2021)
Forest Biomass	49	Average	Xu et al. (2021)
Forest Residue	72	Point calculation	Cuellar and Herzog (2015)
Considering Avoided Emissions			
Biomass	(410)	Point calculation	Spath and Mann (2004)
Biomass	0 to (900)	Point calculations	IPCC (2011)
Mill Residue	(1000)	Point calculation	EPRI (2013)
Biomass	0 to (1000)	Point calculations	NREL (2021)
Considering Avoided Emissions and Engineered Carbon Mitigation (Carbon Capture and Storage)			
Biomass	(667) to (1368)	Point calculations	Spath and Mann (2004)
Biomass	(600) to (1368)	Point calculations	IPCC (2011)
Biomass	(600) to (1368)	Point calculations	NREL (2021)
Forest Residue	(1818)	Point calculation	Cuellar and Herzog (2015)

When avoided emissions are considered, life cycle GHG emission intensities for stand-alone biomass to electricity generation become negative, ranging from (400) to (1380) g CO₂e/kWh. Additional GHG savings can be achieved with the employment of engineered GHG mitigation strategies such as bioenergy carbon capture and storage (BECCS). It is important to note that BECCS installations at pulp

⁵ Biomass refers primarily to woody residuals from manufacturing but also wastewater treatment plant residuals, paper recycling residuals, residuals from forest harvesting, and other miscellaneous biomass fuels used by the US pulp and paper sector.

and paper mills are currently not widespread and only exist at the demonstration or pilot scale. A review of the state of carbon capture in the pulp and paper sector is provided in the NCASI white paper “Toward a Net Zero Future for the Forest Products Industry” (2023b). Considering BECCS, life cycle GHG emission intensities for biomass to electricity generation of (1365) to (1818) g CO₂e/kWh can be achieved. A summary of study results is provided in Table 1. It is important to note that previous studies focused on stand-alone biomass electricity generation plants while this white paper provides information on the life cycle GHG emission characteristics of biomass-derived electricity from US pulp and paper facilities.

Figure 3 shows meta-analyses life cycle GHG emission estimates from bio-based electricity generation from the “Bioenergy” chapter of the Intergovernmental Panel on Climate Change (IPCC) special report on renewable energy sources and climate change mitigation (IPCC 2011). Median life cycle emissions were 42 g CO₂e/kWh. When avoided emissions are considered, emissions of up to (900) g CO₂e/kWh are calculated, and when engineered GHG mitigation approaches such as BECCS are considered in addition to avoided emissions, emissions of (600) to (1368) g CO₂e/kWh are calculated. Again, carbon capture installations at pulp and paper mills are currently not widespread and only exist at the demonstration or pilot scale.

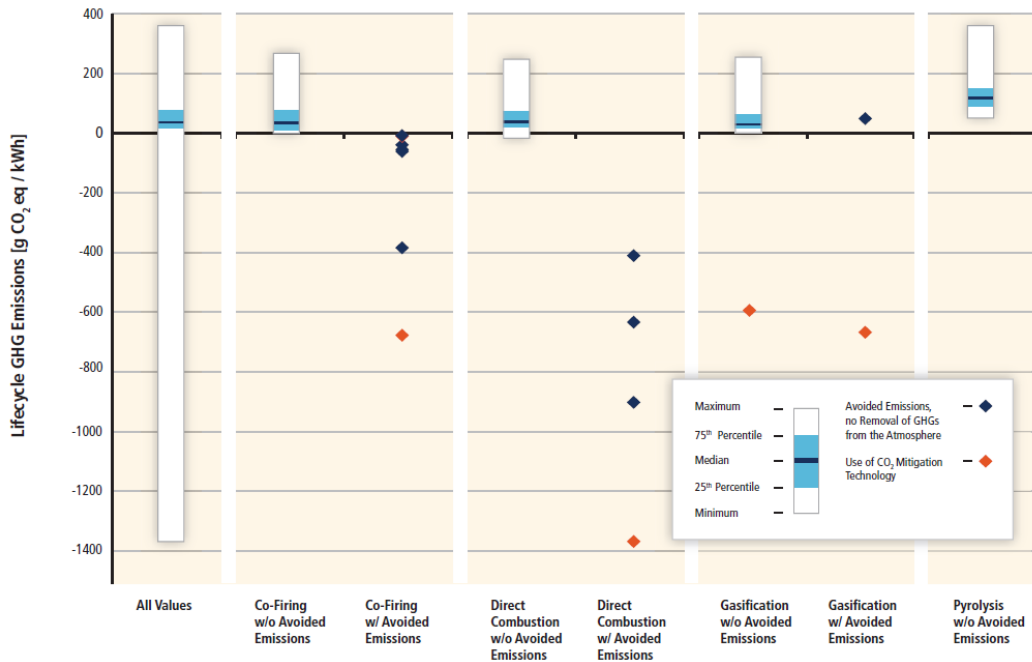

Figure 3. Life Cycle GHG Emission Estimates from Bio-Based Electricity Generation [Source: IPCC (2011)]

Figure 4 shows harmonized meta-analyses of life cycle GHG emission estimates from all major energy sources used for electricity generation (NREL 2021). NREL’s life cycle harmonization project is a meta-analytical procedure to assess and reduce the variability of life cycle assessment results (Heath and Mann 2012). Median, harmonized life cycle emissions for biomass-derived electricity generation were 52 g CO₂e/kWh. When avoided emissions are considered, emissions of up to (1000) g CO₂e/kWh are calculated, and when engineered GHG mitigation approaches such as BECCS are considered in addition to avoided emissions, emissions of (600) to (1368) g CO₂e/kWh are calculated.

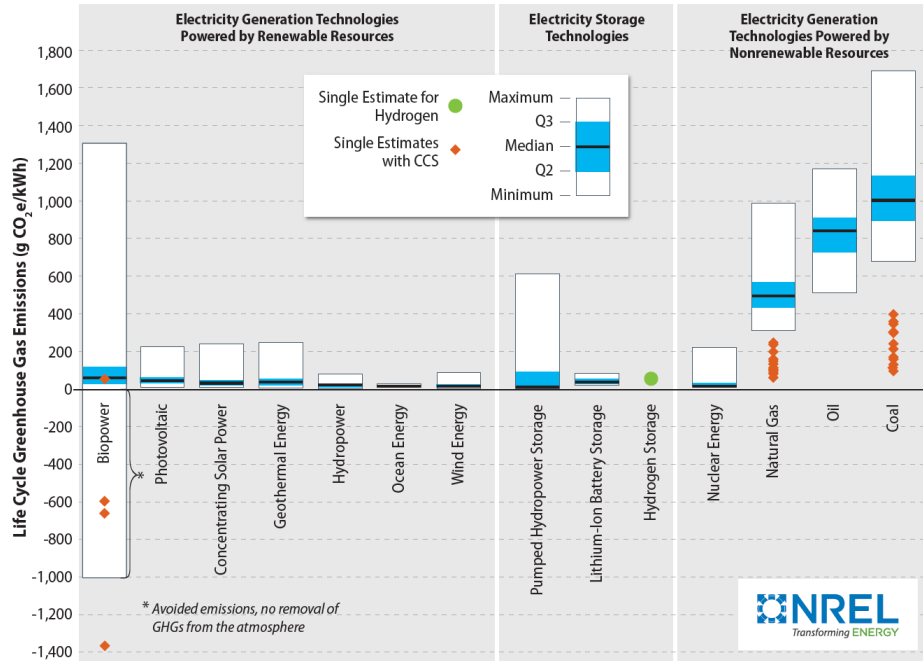

Figure 4. Life Cycle GHG Emission Estimates from Electricity Generation and Storage Technologies and Some Technologies Integrated with Carbon Capture and Storage (NREL 2021)

Figure 5 and Figure 6 show life cycle GHG emission estimates for different types of biomass used for electricity generation (EPRI 2013). Median, harmonized life cycle emissions for electricity generation from mill biomass residues were 15 g CO₂e/kWh. When avoided emissions are considered, negative emissions of (1000) g CO₂e/kWh were calculated (point emission calculation).

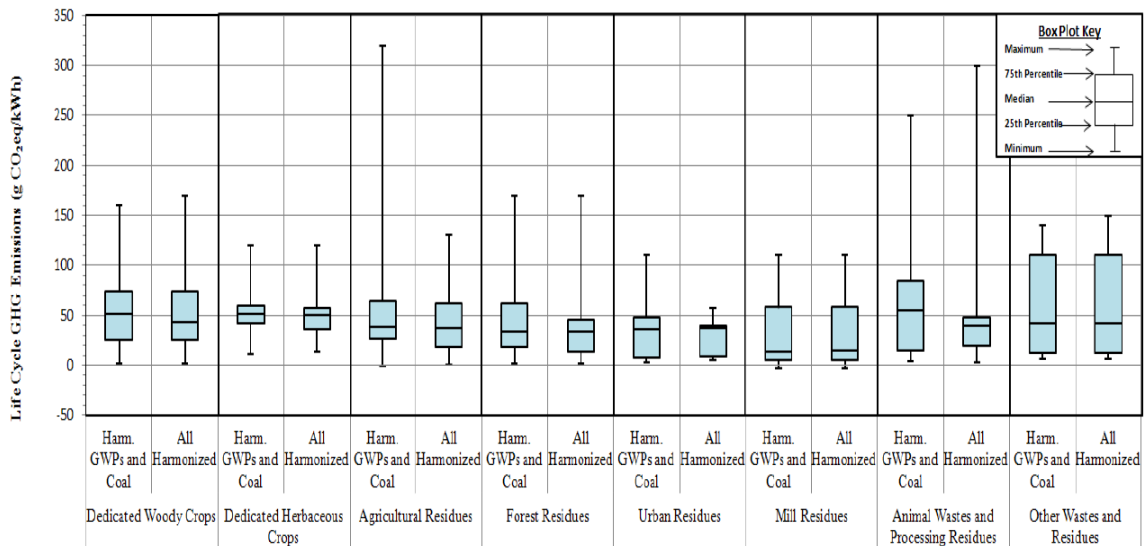

Figure 5. Distribution of Life Cycle GHG Emission Estimates from Electricity Generation by Feedstock Categories (EPRI 2013)

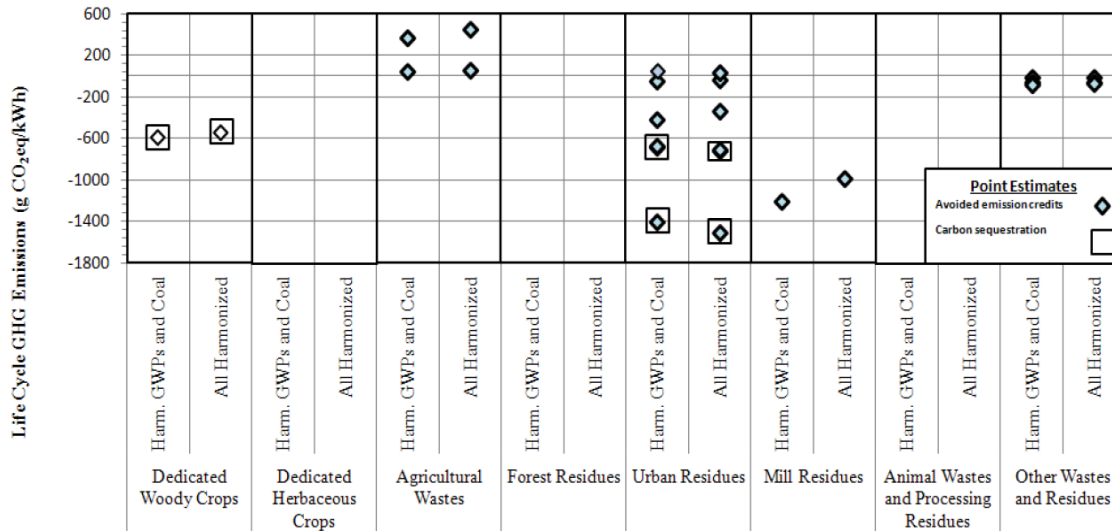

Figure 6. Point Estimates of Life Cycle GHG Emission Estimates from Electricity Generation by Feedstock Categories (EPRI 2013)

Xu et al. studied the regionality of life cycle emissions within the US for forest biomass-derived electricity (2021), shown in Figure 7. Forest biomass-derived electricity has 86% to 93% lower life cycle GHG emissions than average grid electricity in the US (Xu et al. 2021). The average of life cycle emissions of forest biomass-derived electricity was 49 g CO₂e/kWh from several US states (Xu et al. 2021).

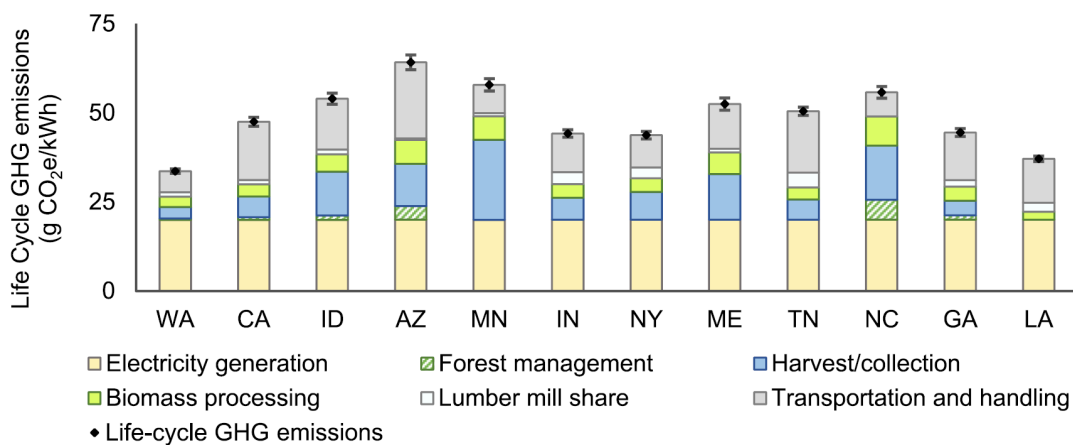

Figure 7. Life Cycle GHG Emission Estimates for Woody Biomass by US State and by Life Cycle Stage (Xu et al. 2021)

4.0 Biomass Fuel Types used for Electricity Generation with the US Pulp and Paper Sector

The forest products sector is unique among industrial sectors in that most energy requirements for the sector are derived from biomass energy sources. In 2018, 63% of fenceline energy needs for the pulp and paper sector and 60% of fenceline energy needs for the wood products sector were derived from biomass fuels. Biogenic CO₂ emissions for the US forest products sector were 137 million mt CO₂e (115 million mt CO₂e from the pulp and paper sector and 22 million mt CO₂e from the wood products

sector) in 2018 and represent a significant opportunity for the sector to become a net negative emitter of GHG emissions if these biogenic emissions are captured with carbon capture technologies. Biomass used by the forest products sector for energy generation is primarily in the form of biomass residuals and biomass by-products and cannot be replaced by alternative energy sources without significant negative GHG emission impacts.

4.1 Spent Liquor Solids

When pulp is produced from wood chips using a chemical pulp process, wood fibers used to make paper and paperboard products are separated from the wood chips in a digester. The residual digester liquid is called spent pulping liquor, which contains the dissolved portion of the wood not needed for pulp and paper making as well as the spent cooking chemicals. Spent pulping liquor is concentrated to then be used as fuel in a recovery furnace (also called a recovery boiler), which is the central component of the mill's recovery system. This system recovers pulping chemicals and energy from the spent pulping liquor. The most common form of spent pulping liquor is black liquor produced by the kraft process. The kraft recovery process is highly resource efficient. Typical chemical recovery efficiencies (a measure of the amount of pulping chemicals recovered and reused for pulping) are approximately 97% (Tran and Vakkilainen 2008), and well-operating bleached kraft mills with low liquor losses into sewers can have chemical recovery efficiencies approaching 99% (NCASI 2023a).

Due to the importance of the kraft process to the pulp and paper sector⁶, NCASI undertook a life cycle-based assessment of the benefits of using black liquor solids (NCASI 2011; Gaudreault et al. 2012). The results from that study include:

- The GHG emissions and non-renewable energy consumption for a system using black liquor solids in the kraft recovery system are approximately 90% lower than those for a comparable fossil fuel-based system.
- Use of black liquor solids in the kraft recovery system avoids approximately 140 kg CO₂e per GJ of energy output from the system.
- Applying these results to the production of kraft pulp in the US, the avoided emissions are approximately 100 million mt CO₂e per year. These avoided emissions are greater than the total of Scope 1 and Scope 2 emissions from the US pulp and paper industry.
- The GHG benefits occur without affecting the amount of wood harvested or the amount of chemical pulp produced.
- The results do not depend on the accounting method for biogenic carbon.
- The findings are valid across a range of assumptions about the displaced fossil fuel, the GHG intensity of the grid, and the fossil fuels used in the lime kiln.
- Even at facilities without CHP cogeneration systems, 80% to 90% of the GHG benefits are retained.

4.2 Manufacturing Biomass Residuals

The use of manufacturing and forest biomass residuals in power boilers is a long-established practice within the forest products industry (both the pulp and paper sector and the wood products sector). Combustion of biomass residuals other than spent liquor solids for energy generation represented 304 trillion Btu of energy in 2018 for the US pulp and paper sector⁷. For the US wood products sector, combustion of biomass residuals represented 233 trillion Btu of energy in 2018. US forest products

⁶ Approximately 90% of wood pulp (pulp derived from chemical pulping, semi-chemical, and mechanical pulping) produced in the United States is from the kraft process.

⁷ US EIA MECS Survey Data. <https://www.eia.gov/consumption/manufacturing/data/2018/>

industry mill manufacturing residuals represent most biomass residuals other than spent liquor solids (Figure 8). Smaller amounts of logging biomass residuals, residuals from wastewater treatment plant operations, paper recycling residuals, and other miscellaneous biomass residuals are utilized by the US forest products industry for energy generation or solid residual minimization. The US pulp and paper sector's contribution from biomass residuals other than spent liquor solids for energy generation is similar to the US forest products industry (Figure 9).

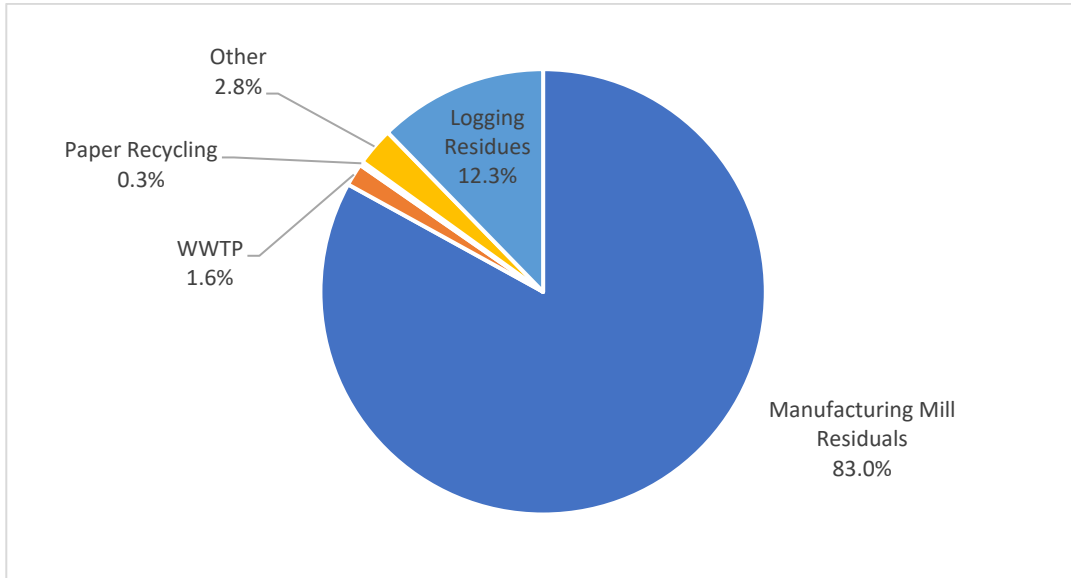

Figure 8. Energy Fractions for US Forest Products Industry's (Both Pulp and Paper and Wood Products Sectors) Biomass Residuals Other Than Spent Liquor Solids

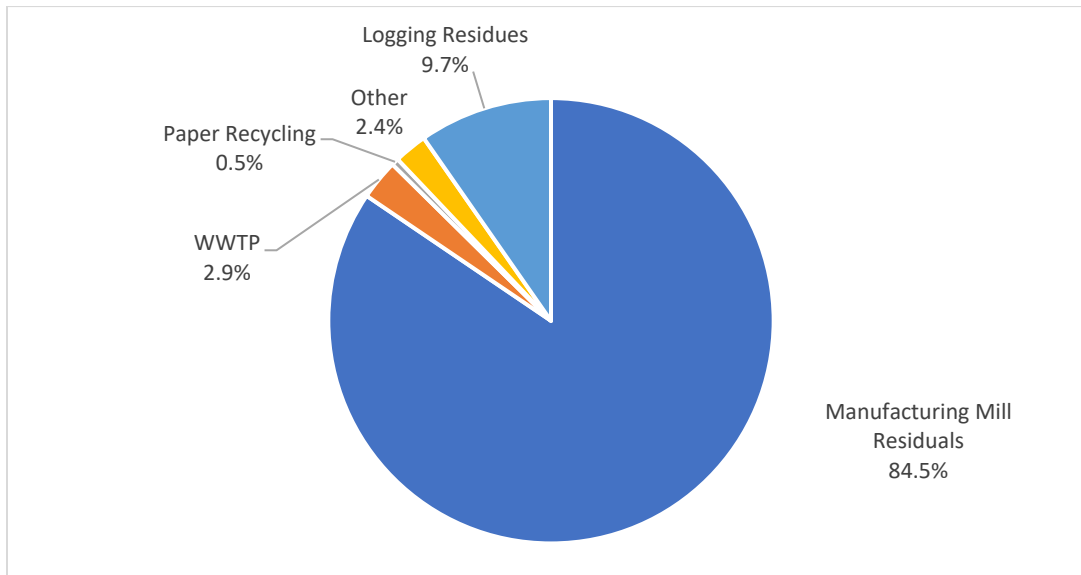

Figure 9. Energy Fractions for the US Pulp and Paper Sector's Biomass Residuals Other Than Spent Liquor Solids

5.0 Combined Heat and Power

The forest products industry is a leader in the use of CHP, also known as cogeneration, which is an energy efficient mode of steam and electricity generation from the same fuel source. Several documents recognize the energy efficiency and resiliency benefits of industrial (including forest products) CHP (US EPA 2008; NREL 2017; DGA et al. 2015). The broad advantages of CHP include:

- The simultaneous production of useful thermal and electrical energy, which is a more efficient generation mode than the separate generation of steam and electricity.
- Installation of CHP units at the point of energy use to avoid transmission and distribution losses that would occur with purchased power.
- Reduced dependency on the grid, particularly during power disruptions or outages.

The US forest products industry currently has 12.7 GW of installed CHP capacity (Table 2).

Table 2. US Forest Products Industry Installed CHP Capacity⁸

Sector	Installed CHP Capacity (GW)
Pulp and Paper	11.8
Wood Products	0.9
Forest Products (total)	12.7

The US forest products industry produced 32% of all the CHP power generated by manufacturing industries in 2018⁹. Over 40 billion kWh of electricity was generated through CHP by the US forest products industry in 2018, representing 95% of all on-site electricity generated by the sector (see Table 3). Pulp and paper and wood product facilities predominantly use biomass-based CHP to generate steam and electricity with very low GHG emissions. The US pulp and paper sector avoids over 12 million mt CO₂e annually by using CHP compared to the separate generation of steam and electricity (Appendix A). The forest products sector sold 6449 million kWh of energy in 2018, which helps contribute to greening the US electrical grid. Given that electricity is being generated at the point of use, forest product CHP systems also contribute to overall electrical grid resiliency, i.e., electricity can still be generated and utilized at a mill even during grid power disruptions or outages. Table 3 shows the US forest products industry electricity generation profile for 2018. Electricity sales within the pulp and paper sector represented 13% of total sector electricity generation and electricity sales within the wood products sector represented 59% of total sector electricity generation.

⁸ U.S. Department of Energy Combined Heat and Power and Microgrid Installation Databases. CHP Data Download. <https://doe.icfwebservices.com/downloads/chp>

⁹ US EIA MECS: "Table 11.3 Electricity: Components of Onsite Generation, 2018." https://www.eia.gov/consumption/manufacturing/data/2018/pdf/Table11_3.pdf

Table 3. The US Forest Products Industry Electricity Generation Profile

Sector	Cogenerated Electricity ^a (million kWh)	Total On-site Electricity Generation ^b (million kWh)	Percentage of On-site Electricity that Is Cogenerated	Sales ^b (million kWh)
Pulp and Paper	38,663	40,518	95%	5372
Wood Products	1735	1840	94%	1077
Forest Products (Total)	40,398	42,358	95%	6449

^a US EIA MECS: "Table 11.3 Electricity: Components of Onsite Generation, 2018."

https://www.eia.gov/consumption/manufacturing/data/2018/pdf/Table11_3.pdf

^b US EIA MECS: "Table 11.1 Electricity: Components of Net Demand, 2018."

https://www.eia.gov/consumption/manufacturing/data/2018/pdf/Table11_1.pdf

A diagram of a typical steam and power balance at a medium-sized kraft mill is provided in Figure 10. Typically, high-pressure steam is produced from a kraft recovery boiler and one or more power boilers. Fuels used in mill power boilers may be biomass fuels or fossil fuels (predominantly natural gas, but small amounts of coal and residual fuel oil may also be used).

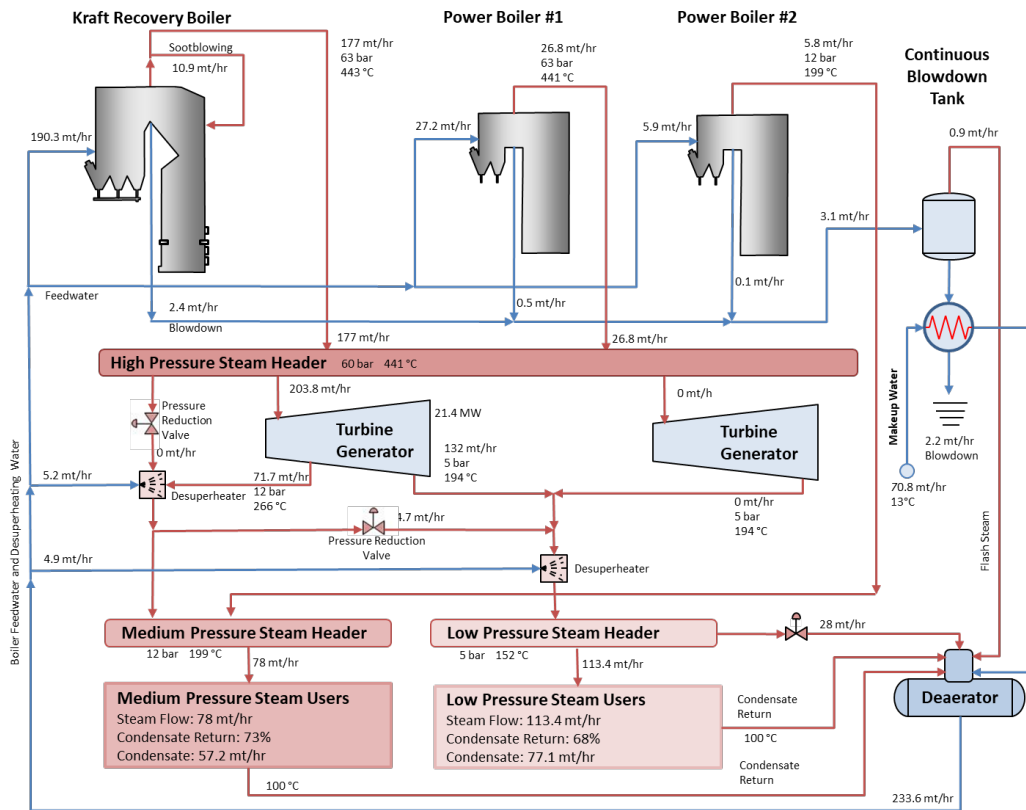

Figure 10. Typical Steam and Power Balance at a Kraft Mill (Reproduced from AGRA Simons 1998)

A simplified block diagram of a chemical pulp mill CHP system is provided in Figure 11. Mill CHP systems typically have multiple biomass or fossil fuels supplying energy to the system. The nature of CHP systems is that they simultaneously produce multiple products (medium- and low-pressure steam to supply mill needs and electricity for use or sale).

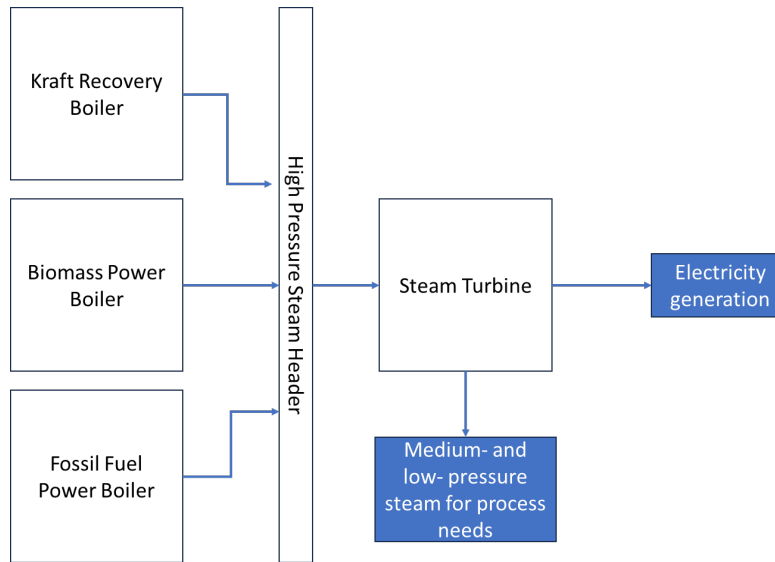

Figure 11. Simplified Block Diagram of a Chemical Pulp Mill Combined Heat and Power System (steam and electricity co-products are highlighted in blue)

In detailed cradle to final energy use life cycle studies on the GHG and fossil fuel reduction benefits of using biomass residuals for energy production (NCASI 2011; Gaudreault et al. 2012; NCASI 2014; NCASI 2017), life cycle GHG emissions were determined for biomass residual fuels used in the US forest products sector. For each type of residual, the NCASI studies compared a base case of no beneficial use of residuals (including their alternative fates) with 100% use for energy generation. A summary of the differential GHG impact indicators is provided in Table 4.

Table 4. Difference in Total Life Cycle GHG Emissions Over 100 Years

Biomass Residual Type	Differential GHG Impact, Dynamic Forcing (kg CO ₂ e/GJ)
Wood Mill Residuals ^a	-116
WWTP Residuals ^a	-295
Paper Recycling Residuals ^a	-112
Spent Liquor (Including Black Liquor) ^b	-184
Forest Harvesting Residuals ^c	-75.7

^a NCASI 2014

^b NCASI 2011; Gaudreault et al. 2012

^c NCASI 2017

The differential GHG impact indicator is defined as:

Differential GHG Impact (kg CO₂E/GJ) = [Total GHG impact caused by GHG releases, including biogenic CO₂ emissions and removals, for energy production using residuals] – [Total GHG impact of GHG releases, including biogenic CO₂ emissions and removals, for energy production using fossil fuels, including alternative fate of residuals] (NCASI 2014).

A summary of GHG mitigation benefits of energy generation from biomass residuals in the US forest products sector is provided in Table 5.

Table 5. Life Cycle GHG Mitigation Benefits for Biomass Residuals Energy Systems in the US Forest Products Sector

Reference	Biomass Type	Fossil Fuels Offset	Type Of Facility in which the Biofuel Is Used	Alternative Fate Considered	GHG Mitigation Compared to a Comparable Fossil Fuel-Based System (%)	Break-even Time (years) ^a
Gaudreault et al. (2012) and NCASI (2011)	Black liquor	Heat (coal and natural gas) or CHP (coal and natural gas for heat and US electricity grid for electricity)	US pulp and paper mills	Biogenic carbon released as CO ₂	69–92	0
NCASI (2014)	Wood mill residuals		US forest products facilities	Landfill or incineration	98.7	1.2
NCASI (2014)	WWTP ^b residuals		US pulp and paper mills	Landfill or incineration	98.7	0
NCASI (2014)	Paper recycling residuals		US pulp and paper mills	Landfill or incineration	86.4	0
NCASI (2017)	Forest residuals		US forest products facilities	Decay or burned on-site	92.5	0

^a Based on dynamic radiative forcing.

^b Wastewater treatment plant.

6.0 Allocation of Life Cycle GHG Emissions to Steam and Electricity

In detailed cradle to final energy use life cycle studies on the GHG and fossil fuel reduction benefits of using biomass residuals for energy production (NCASI 2011; Gaudreault et al. 2012; NCASI 2014; NCASI 2017), the functional unit was the production of 1 GJ of energy. Given that over 95% of the on-site electricity in the US pulp and paper sector is generated from CHP systems, allocation approaches to allocate both GHG burdens and benefits are required to quantify the GHG characteristics of industry-generated biomass-derived electricity. Appendix B provides a detailed overview of the most common GHG allocation approaches applied to the US pulp and paper sector. Depending on the approach, different fractional allocation amounts are attributed to heat or electricity (Table 6).

Table 6. US Pulp and Paper Sector GHG Allocation Fractions for CHP Systems by Method

Allocation Method	Fraction Allocated to Electricity		Fraction Allocated to Heat	
	f_E		f_Q	
Energy Content	0.13		0.87	
Incremental Fuel Consumption (Electricity)	0.21		0.79	
Work Potential Method	0.22		0.78	
Incremental Fuel Consumption (Steam)	0.24		0.76	
Simplified Efficiency Method	0.26		0.74	
Economic Value Method	0.50		0.50	

Avoided GHG emissions can be determined by the use of the differential GHG impact indicators in Table 4 and current energy consumption information for biomass residuals for the US pulp and paper sector (Appendix A). Table 7 shows the calculated avoided emissions on an absolute basis and life cycle GHG emission intensities allocated to electricity production for the US pulp and paper sector.

Table 7. Life Cycle GHG Emission Characteristics of Biomass-derived Electricity Considering Avoided Emissions for the US Pulp and Paper Sector

Biomass Residual	Avoided GHG Emissions (million mt CO ₂ e)	Life Cycle GHG Emission Intensities Allocated to Electricity Production	
		Low (kg CO ₂ e/MWh)	High (kg CO ₂ e/MWh)
Spent Pulping Liquor	119	(709)	(2814)
All Other Biomass Residuals	25	(482)	(1812)

Electricity efficiencies (the ratio of power output to fuel input on a higher heating value energy basis) of systems designed for the exclusive generation of electricity are higher than in CHP systems. New ultra-supercritical coal-based electricity generation plants have electricity efficiencies of 40% (heat rate of 8368 Btu/kWh), and new natural gas combined cycle multi-shaft electricity generation plants have electricity efficiencies of 54% (heat rate of 6370 Btu/kWh) (US EIA 2023). In a meta-analysis of life cycle GHG emissions of coal-fired electricity generation, electricity efficiencies ranged from 27% to 49%, and a collective harmonized arithmetic weighted mean thermal efficiency was 33% (Whitaker et al. 2012). In a meta-analysis of life cycle GHG emissions of natural gas fired electricity generation, electricity efficiencies ranged from 43% to 50% (O’Donoghue et al. 2014). Because of the higher electricity efficiencies for stand-alone plants, allocated emissions from CHP systems can be greater than from electricity-only plants (column 2 of Table 8).

Table 8. Life Cycle GHG Emission Characteristics of Fossil Fuel Derived Electricity

Fossil Fuel Used in the Pulp and Paper Sector	Total Life Cycle Emissions for Electricity Production (kg CO ₂ e/MWh) ^a	Life Cycle GHG Emission Intensities Allocated to Electricity Production (kg CO ₂ e/MWh)	
		Low	High
Natural Gas	486	296	1137
Coal	1001	411	1581

^a NREL 2021

In a detailed study of combined heat and power generation and the avoided emissions from the energy efficiency improvement of CHP systems compared to the separate generation of steam and electricity (Appendix A), the fuel and energy usage and energy generation characteristics of 177 US pulp and paper mills were aggregated and assessed to generate GHG information on average and total CHP generation in the US pulp and paper sector. In 2018, 24% of steam and power from US pulp and paper sector CHP systems were derived from fossil fuels (19% natural gas, 3% coal, 2% other fossil fuels) (Appendix A and Figure 12).

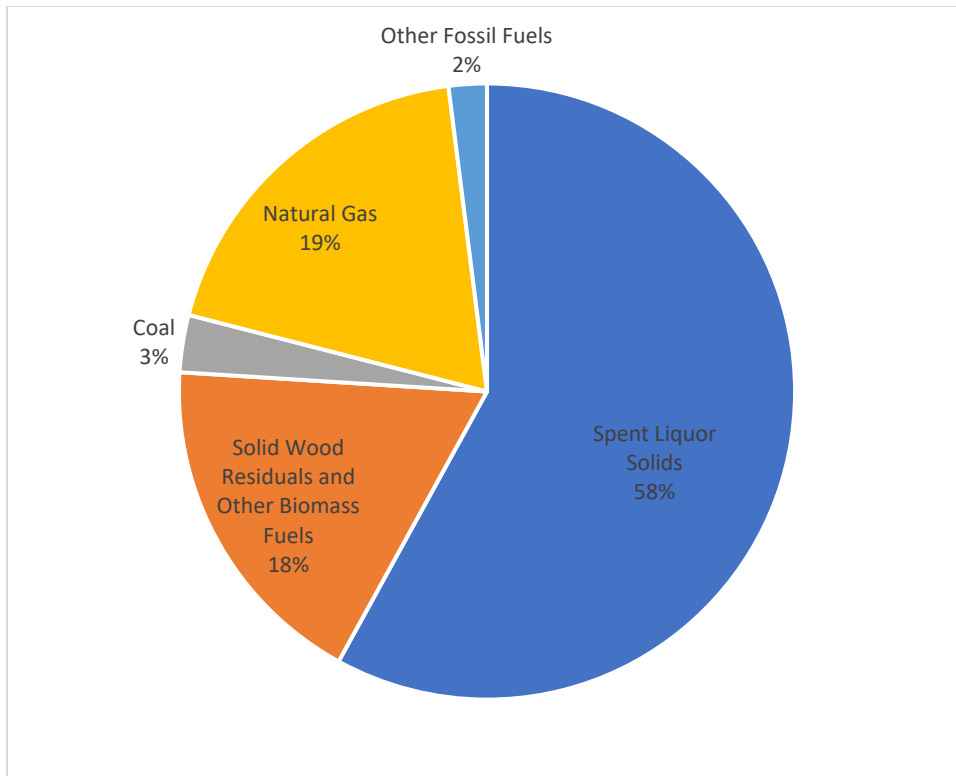

Figure 12. Fuels Used in US Pulp and Paper Sector Cogeneration Systems in 2018

The emission factor for a CHP system using multiple fuels can be calculated as:

$$EF_{CHP} = \frac{\sum_{i=1}^{i=n} (F_{fuel_i} \cdot \eta_{eff_i}) \cdot EF_i}{\sum_{i=1}^{i=n} (F_{fuel_i} \cdot \eta_{eff_i})}$$

Where:

- F_{fuel} : fuel fraction on a higher heating value energy basis
- EF : emission intensities for electricity generation for biomass fuels (Table 7) or fossil fuels (Table 8)
- η_{eff} : boiler thermal efficiency by fuel (Appendix A, Table A4)

Emission intensities attributed to electricity generation from biomass fuels (Table 7), fossil fuels (Table 8), and typical boiler thermal efficiencies by fuel (Appendix A, Table A4), can be used in the above equation to calculate composite emission intensities from mill-produced electricity. Under a typical scenario where 24% of the fuel was supplied from either natural gas or coal, industry derived electricity is still significantly negative from a GHG perspective when avoided emissions from the utilization of biomass fuels are considered (Table 9).

Table 9. GHG Emission Characteristics of US Pulp and Paper Sector Produced Electricity

Mill Fossil Fuel Fraction for Energy Generation ^a	Life Cycle GHG Emission Intensities Allocated to Electricity Production	
	Low (kg CO ₂ e/MWh)	High (kg CO ₂ e/MWh)
24% Coal	(346)	(1368)
24% Natural Gas	(388)	(1534)
19% Natural Gas, 5% Coal	(379)	(1499)

^a 58% of energy is derived from black liquor, and 18% is derived from other biomass fuels.

7.0 Conclusions

This white paper provides information regarding the life cycle GHG characteristics of biomass-derived electricity from the US pulp and paper sector. When avoided emissions are considered, life cycle GHG emission intensities for industry-generated electricity derived from spent liquor solids and all other major biomass types utilized by the sector are highly negative. Even when a portion of the on-site electricity generation at a pulp and paper mill is derived from supplemental fossil fuels, as is typical for the US pulp and paper sector, the large negative (i.e., avoided) emissions from utilizing biomass residuals more than offset the life cycle GHG emission amounts from the use of fossil fuels, resulting in negative emissions for industry-generated electricity.

References

- AGRA Simons and Pulp and Paper Technical Association of Canada. 1998. *A Guide to Energy Savings Opportunities in the Kraft Pulp Industry*. AGRA Simons Limited: Vancouver, BC; Pulp and Paper Technical Association of Canada: Brossard, QC.
- Cuellar, Amanda D., and Howard Herzog. 2015. "A Path Forward for Low Carbon Power from Biomass." *Energies* 8, no. 3: 1701–1715. <https://doi.org/10.3390/en8031701>.
- David Gardiner and Associates (DGA), Institute for Industrial Productivity, and Wooley Energy & Environment. 2015. Combined Heat and Power (CHP) as a Compliance Option Under the Clean Power Plan: A Template and Policy Options for State Regulators. https://chpalliance.org/wp-content/uploads/2016/05/CHP-Pathway_Full-Report_Final.pdf.
- US EIA (Energy Information Administration). March 2023. Cost and Performance Characteristics of New Generating Technologies, Annual Energy Outlook 2023. Washington, D.C. https://www.eia.gov/outlooks/aeo/assumptions/pdf/elec_cost_perf.pdf.
- US EPA (Environmental Protection Agency). 2017. Catalog of CHP Technologies. https://19january2021snapshot.epa.gov/sites/static/files/2015-07/documents/catalog_of_chp_technologies.pdf.
- EPRI (Electric Power Research Institute). 2013. "Literature Review and Sensitivity Analysis of Biopower Life-Cycle Assessments and Greenhouse Gas Emission." Palo Alto, CA. <https://www.epri.com/research/products/1026852>.
- Gaudreault, Caroline, Barry Malmberg, Brad Upton, and Reid Miner. 2012. "Life Cycle Greenhouse Gases and Non-Renewable Energy Benefits of Kraft Black Liquor Recovery." *Biomass and Bioenergy* 46:683–692. <https://doi.org/10.1016/j.biombioe.2012.06.027>.
- Heath, Garvin A., and Margaret K. Mann. 2012. "Background and Reflections on the Life Cycle Assessment Harmonization Project." *Journal of Industrial Ecology* 16, no. S1:S8–S11. <https://doi.org/10.1111/j.1530-9290.2012.00478.x>.
- Chum, Helena, Andre Faajj, José Moreira, Göran Berndes, Parveen Dhamija, Hongmin Dong, Benoît Gabrielle, Alison Goss Eng, Wolfgang Lucht, Maxwell Mapako, Omar Masera Cerutti, Terry McIntyre, Tomoaki Minowa, and Kim Pingoud. 2011. "Bioenergy." In *IPCC Special Report on Renewable Energy Sources and Climate Change Mitigation*: 209–332. Cambridge, UK and New York, US: Cambridge University Press. <https://archive.ipcc.ch/pdf/special-reports/srren/Chapter%20%20Bioenergy.pdf>.
- NCASI (National Council for Air and Stream Improvement, Inc). April 2011. Greenhouse Gas and Non-Renewable Energy Benefits of Black Liquors Recovery. Technical Bulletin No. 984. Research Triangle Park, N.C.
- . October 2013 (revised August 2014). Greenhouse gas and fossil fuel reduction benefits of using biomass manufacturing residuals for energy production in forest products facilities. Technical Bulletin No. 1016. Research Triangle Park, N.C.
- . 2017. Greenhouse Gas Aspects of Using Forest Residuals for Energy Production in Forest Products Facilities. Technical Bulletin No. 1042. Research Triangle Park, N.C.
- . November 20, 2023a. Liquor Cycle Sodium Make-up Requirements at Kraft Pulp Mills. Technical Memorandum. Research Triangle Park, N.C.

- . 2023b. Toward a Net Zero Future for the Fores Products Industry. White Paper WP-23-04. Research Triangle Park, N.C.
- NREL (National Renewable Energy Laboratory). 2017. Combined Heat and Power Evaluation Protocol. The Uniform Methods Project: Methods for Determining Energy Efficiency Savings for Specific Measures. NREL/SR-7A40-68579.
- . 2021. Life Cycle Greenhouse Gas Emissions from Electricity Generation: Update. NREL/FS-6A50-80580.
- O’Donoughue, Patrick R., Garvin A. Heath, Stacey L. Dolan, and Martin Vorum. 2014. “Life Cycle Greenhouse Gas Emissions of Electricity Generated from Conventionally Produced Natural Gas: Systematic Review and Harmonization.” *Journal of Industrial Ecology* 18, no. 1: 125–144. <https://doi.org/10.1111/jiec.12084>.
- Spath, Pamela L., and Margaret K. Mann. 2004. Biomass Power and Conventional Fossil Systems with and without CO₂ Sequestration – Comparing the Energy Balance, Greenhouse Gas Emissions and Economics. NREL/TP-510-32575. National Renewable Energy Laboratory, Golden, CO, USA.
- Tran, Honghi, and Esa K. Vakkilainen. 2008. “The Kraft Chemical Recovery Process.” Technical Association of the Pulp and Paper Industry. <https://www.tappi.org/content/events/08kros/manuscripts/1-1.pdf>
- Turconi, Roberto, Alessio Boldrin, and Thomas Astrup. 2013. “Life Cycle Assessment (LCA) of Electricity Generation Technologies: Overview, Comparability and Limitations.” *Renewable and Sustainable Energy Reviews* 28: 555–565. <https://doi.org/10.1016/j.rser.2013.08.013>.
- Whitaker, Michael, Garvin A. Heath, Patrick O’Donoughue, and Martin Vorum. 2012. “Life Cycle Greenhouse Gas Emissions of Coal-Fired Electricity Generation: Systematic Review and Harmonization.” *Journal of Industrial Ecology* 16(S1): S53–S72. <https://doi.org/10.1111/j.1530-9290.2012.00465.x>
- Xu, Hui, Gregory Latta, Uisung Lee, Jan Lewandrowski, and Michael Wang. 2021. “Regionalized Life Cycle Greenhouse Gas Emissions Of Forest Biomass Use For Electricity Generation in the United States.” *Environmental Science & Technology* 55, no. 21:14806–14816.

Appendix A: Avoided GHG Emissions from the Use of CHP in the US Pulp and Paper Industry

CHP is the sequential or simultaneous generation of useful thermal and electrical energy in a single integrated system. CHP is more energy efficient at generating steam and electricity than the separate generation of steam and electricity and can therefore result in fuel savings and GHG emission reductions.

One method of evaluating the efficiency of CHP systems within the pulp and paper industry is to compare emissions from CHP operation to emissions from the separate generation of equivalent amounts of steam for process use and electrical power. Avoided GHG emissions in 2018 due to the use of CHP for the US pulp and paper industry were 12.2 million mt CO₂e (Table A1). To put these avoided emissions in context, combined direct and indirect GHG emissions from the US pulp and paper industry were 53.0 million mt CO₂e in 2018 (Appendix A). Use of CHP technology in the US pulp and paper industry reduced GHG emissions by 34% compared to what they would have been if those mills had generated steam in stand-alone generation units and purchased all required electricity from the power grid (34.9 million mt CO₂e compared to 23.6 million mt CO₂e from CHP operation). In addition to the energy efficiency savings from the utilization of industry CHP, biomass residuals comprise approximately 76% of fuels consumed in US pulp and paper industry cogeneration systems.

Operation of CHP systems does increase on-site emissions compared to emissions from steam generation in stand-alone boilers. The increase in on-site GHG emissions from CHP utilization was 4.0 million mt CO₂e in 2018 for the US pulp and paper industry. However, this increase in on-site emissions is more than offset by the reduced need for purchased utility-generated power.

Table 10. US Pulp and Paper Industry GHG Emissions from Use of CHP Technology in 2018 Compared to the Separate Generation of Heat and Power

Population	GHG Emissions (million mt CO ₂ e)				Avoided GHG Emissions
	CHP Operation	Separate Generation of Electricity ^a	Separate Generation of Steam ^b	Difference in On-site Emissions	
Mill-specific Information	20.2	13.9	16.8	3.5	10.5
US Pulp and Paper Industry	23.6	16.2	19.6	4.0	12.2

^a GHG emissions due to purchase of electricity equivalent to amount generated from CHP operation.

^b GHG emissions from separate generation of steam to meet process needs, equivalent to amount from CHP operation, and based on the same fuel mix to generate combined heat and power.

Calculation Procedure

Mill-specific environmental and energy data are collected biennially by the American Forest and Paper Association (AF&PA) and by NCASI for US pulp and paper mills. The latest year of quality assured data for the AF&PA/NCASI data set is from 2018 and represents approximately 85% of the total paper, paperboard, and market pulp production in the US. Of the 176 mills in the AF&PA/NCASI database, 97

facilities with combined production of 57.5 million short tons reported 33,143 million kWh of cogenerated electricity in the 2018. These data served as the basis for this cogeneration analysis and are called the “Environmental Health and Safety (EHS) database” throughout this white paper. Mills report total site level energy consumption on a high heating value basis. Only energy consumed in CHP systems (either boiler/steam turbine systems or direct fired turbine systems) should be considered when calculating avoided GHG emissions from CHP. Fuels consumed in lime kilns, mobile sources, incinerators, generators, tissue dryers, etc. should be excluded, as well as fuel consumed in boilers that operate solely for steam production or electricity production. Figure A1 shows a schematic that was followed to translate site level EHS data to a form usable to calculate avoided GHG emissions from CHP systems.

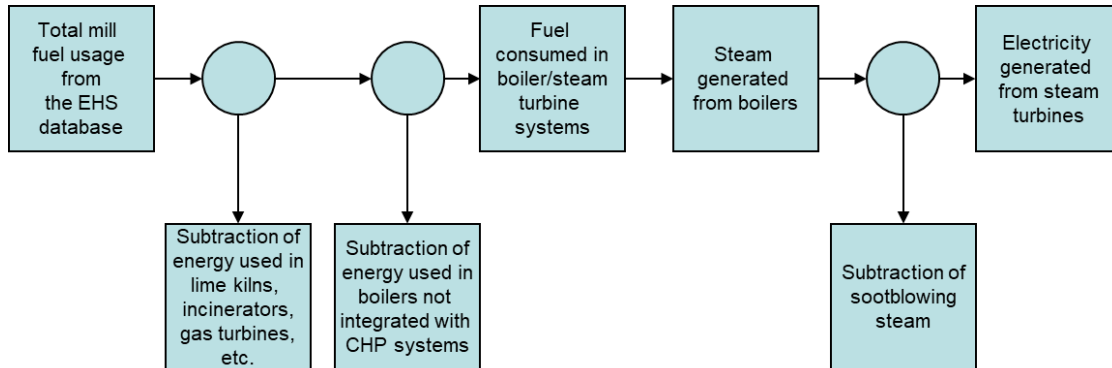

Figure 13. Schematic Used to Translate EHS Data to Steam and Electricity Generation in Pulp and Paper CHP Systems

Energy Used in Lime Kilns, Total Reduced Sulfur Incinerators, and Gas Turbines

NCASI maintains a database (latest quality assured information from 2010) of combustion devices for the US pulp and paper industry (NCASI 2010). The NCASI combustion source database was cross-referenced with the EHS database to subtract the energy consumption from lime kilns, TRS incinerators, and gas turbines from total reported mill energy use. Table A2 shows the total energy consumption contributions from lime kilns, TRS incinerators, and gas turbines from facilities that also reported on-site cogeneration.

Table 11. Energy Consumption from Lime Kilns, TRS Incinerators, and Gas Turbines

Fuel	Lime Kilns (billion Btu HHV)	TRS Incinerators (billion Btu HHV)	Gas Turbines (billion Btu HHV)
Natural Gas	44,843	1910	8432
Residual Fuel Oil	13,401	100	
Petroleum Coke	3672		
Total Energy Consumption	61,916	2009	8432

HHV=high heating value

Total energy use from mills reporting on-site cogeneration was reduced by subtracting energy consumption from lime kilns, TRS incinerators, and gas turbines at these facilities. It is assumed that the remaining energy is available for cogeneration. Table A3 shows the amount of fuel energy available for

cogeneration by fuel type. Approximately 76% of fuels consumed in US pulp and paper industry cogeneration systems are from biomass residuals. It is assumed that reported liquefied petroleum gas, gasoline, kerosene, and minor fossil fuels that fall under the “Other Fuel” or “Other Fuel 1” categories in the EHS database are not used in CHP systems.

Table 12. 2018 Fuels Used for Cogeneration

Fuel	Cogeneration Fuels ^a (billion Btu)	Cogeneration Fuels (% energy content basis)
Biomass Fuels		
Spent Liquor Solids	759,909	58%
Solid Wood Residuals and Other Biomass Fuels	242,884	18%
Fossil Fuels		
Coal	44,713	3%
Natural Gas	255,449	19%
Rubber Tire Chips	6847	1%
Petroleum Coke	10,084	1%
Sum	1,319,886	100%

^a Fuels calculated to be consumed in boiler/steam turbine CHP systems by 2018 EHS survey respondents that reported electrical cogeneration.

The amount of steam production based on cogeneration fuel input is calculated using the boiler thermal efficiencies in Table A4, the properties of superheated high-pressure steam and boiler feedwater in Table A5, and Equation 1. The calculated amount of high-pressure steam generated from the cogeneration fuels in Table A3 was 647,120 million pounds in 2018 (919,826 billion Btu).

Table 13. Boiler Thermal Efficiencies Based on Fuel Type

Fuel	Boiler Thermal Efficiency (η)
Spent Liquor Solids	0.65
Solid Wood Residuals and Other Biomass Fuels ^a	0.70
Coal	0.84
Natural Gas	0.80
Rubber Tire Chips	0.80
Petroleum Coke	0.84

^a Includes all hogged fuels, other biomass, non-recyclable paper, and sludge.

Table 14. Steam and Feedwater Conditions Used in CHP Analysis

Stream	Pressure (psig)	Temperature (°F)	Specific Enthalpy ^a (Btu/lb)
High-pressure Steam	1073	860	1421
Medium-pressure Steam	130	386	1213
Low-pressure Steam	36	282	1175
Boiler Feedwater	36	282	251

^a Verma, Mahendra P. 2003. "Steam Tables for Pure Water as an ActiveX Component in Visual Basic 6.0." *Computers & Geosciences* 29: 1155–1163.

$$F = \eta \cdot \text{Input} / (H_S - H_{FW}) \tag{Eq. 1}$$

Where:

- F*: flow of high-pressure superheated steam generated from boiler (lb/yr)
- η*: boiler energy to steam efficiency (fraction)
- Input: fuel energy input to boiler (Btu/yr)
- H_S*: specific enthalpy of high-pressure steam (Btu/lb)
- H_{FW}*: specific enthalpy of boiler feedwater (Btu/lb)

Depending on the fuel type, a certain percentage of the high-pressure superheated steam is assumed to be used for soot-blowing purposes. Soot-blowing steam requirements based on fuel type are given in Table A6. After subtracting soot-blowing steam use, the amount of high-pressure steam calculated to be entering steam turbines was 621,235 million pounds in 2018 (883,032 billion Btu).

Table 15. Soot-blowing Steam Requirements Based on Fuel Type

Fuel	Steam Generation Used in Soot-blowing (% of High-pressure Steam)
Spent Liquor Solids	6.5
Wood/Bark ^a	2.0
Coal, Petroleum Coke, and Rubber Tire Chips	2.5
Natural Gas	0.0

^a Includes all hogged fuels, other biomass, and non-recyclable paper.

Power Production from Steam Turbines

Power generated from steam turbines was calculated by using a high-pressure steam to power conversion factor for all cogeneration fuels. This factor is the fraction of high-pressure steam energy content entering a turbine that is converted to electrical power. The conversion factor of 0.12 was tuned (after adjusting for CHP power generated from gas turbines in mills that reported cogeneration) to match the reported 33,143 million kWh of cogenerated electricity in the EHS database. Assuming no

energy losses and negligible energy content in any condensates, the high-pressure steam to power conversion factor of 0.12 translates to a power to steam ratio of 0.14 (equivalent to 40 kWh/GJ of steam generated). Power to steam ratios for the pulp and paper industry range from 0.07–0.25 for back-pressure steam turbines and 0.1–0.5 for condensing turbines (Strickland and Nyober 2002).

Gas Turbines

The amount of natural gas consumed in gas turbines from mills that reported both cogenerated electricity and a gas turbine installation is 8,432 billion Btu (Table A2). The fuel consumption, electricity generation, and performance parameters for a gas turbine generator (GTG), heat recovery steam generator (HRSG), and extraction condensing steam turbine generator system are taken from McCann (2002) and are used to calculate steam and electricity generation from gas turbines.

Avoided GHG Emissions from CHP

Avoided GHG emissions due to CHP technology are calculated by comparing emissions from the separate generation of heat and power to those from combined generation of heat and power. From a process standpoint, steam of pressure higher than 10 to 12 bar (typically referred to as medium-pressure steam) is not needed. On-site GHG emissions from mills generating high-pressure steam that is subsequently expanded within a turbine for power generation and extracted for process needs will be higher than those from a mill generating medium-pressure steam in a HRSG and pressure reducing a portion of it to meet low-pressure steam requirements. Figures A2 and A3 show schematics for generating the same amounts of electricity and steam in a CHP system and separately.

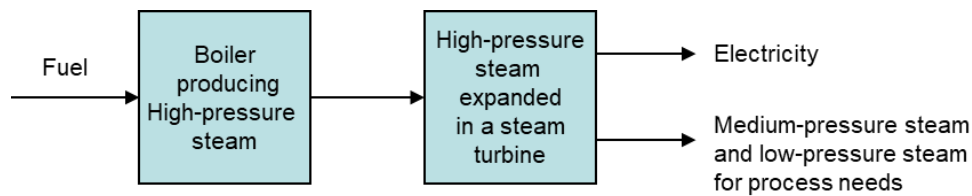

Figure 14. Steam and Electricity Generation in a CHP System

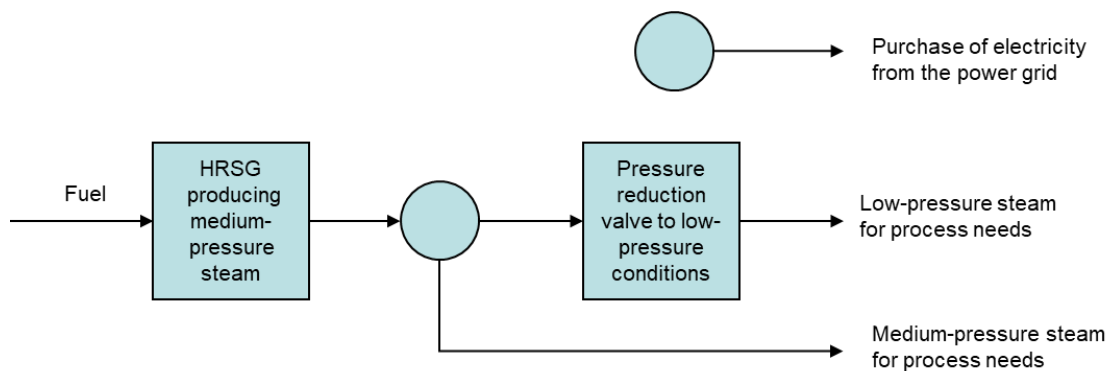

Figure 15. Separate Generation of Steam and Electricity (same amounts as in Figure A2)

GHG emissions from steam and electricity generated in CHP systems are calculated based on fuel amounts used in cogeneration (Table A3), natural gas used in gas turbines (Table A2), and IPCC and World Resources Institute (WRI)/World Business Council for Sustainable Development (WBCSD) fuel-specific emission factors and global warming potentials. Fuel-specific emission factors and global

warming potentials from the IPCC (IPCC 2006) were used, with the exception of those for CH₄ and N₂O from biomass combustion, where factors from WRI/WBCSD (2005) were used. The total GHG emissions calculated in this fashion are 20.2 million mt CO₂e/yr. GHG emissions from the purchase of an equivalent amount of grid electricity as self-generated CHP electricity (33,143 million kWh) is calculated using the US average grid power emission intensity value of 0.432 mt CO₂e/MWh¹⁰ and results in GHG emissions of 13.9 million mt CO₂e/yr. The fuel energy needed to generate an equivalent amount of steam as that produced in CHP systems (647,120 million pounds) is calculated using enthalpies for medium-pressure steam and feedwater (Table A5), boiler thermal efficiencies (Table A4), Equation 2 (a rearranged form of Equation 1), and steam mass flows from cogeneration fuels.

$$\text{Input} = F \cdot (H_S - H_{FW})/\eta \quad (\text{Eq. 2})$$

GHG emissions from separate generation of steam are 16.0 million mt CO₂e/yr. Avoided GHG emissions from CHP operation are calculated by summing the emissions attributed to purchased electricity and the separate generation of steam minus emissions from CHP operation. Avoided GHG emissions from all mills in the EHS database that reported cogenerated electricity are 10.5 million mt CO₂e/yr.

Scale-Up to Total US Production

The scale-up of avoided emissions calculated from the EHS database to total US pulp and paper production was accomplished by ratioing total in-plant cogeneration reported in the 2018 US Energy Information Administration (EIA) Manufacturing Energy Consumption Survey (MECS)¹¹, which is assumed to have complete coverage for the sector, to in-plant cogeneration reported by facilities in the EHS database. In-plant cogeneration from the 2018 EIA MECS was 38,663 million kWh and in-plant cogeneration from facilities from the EHS database was 34,059 million kWh. The ratio of 38,663 to 33,143 (scaling factor 1.17) was used to scale results to the US pulp and paper sector in Table A1.

¹⁰ <https://www.epa.gov/egrid>

¹¹ US EIA MECS: "Table 11.3 Electricity: Components of Onsite Generation, 2018." https://www.eia.gov/consumption/manufacturing/data/2018/pdf/Table11_3.pdf

Appendix A References

- IPCC (Intergovernmental Panel on Climate Change). 2006. *2006 IPCC Guidelines for National Greenhouse Gas Inventories*, edited by Simon Eggleston, Leandro Buendia, Kyoko Miwa, Todd Ngara, and Kiyoto Tanabe. IPCC National Greenhouse Gas Inventories Programme. <https://www.ipcc-nggip.iges.or.jp/public/2006gl/>.
- McCann, Derek. 2002. A Review of the Applications of Gas Turbine Generators to the Pulp and Paper Industry. *Pulp & Paper Canada*. 103, no. 1:T12–T15.
- NCASI (National Council for Air and Stream Improvement, Inc.). July 2005. Calculation Tools for Estimating Greenhouse Gas Emissions from Pulp and Paper Mills. Version 1.1. The Climate Change Working Group of The International Council of Forest and Paper Associations (ICFPA). Research Triangle Park, N.C.: NCASI. https://ghgprotocol.org/sites/default/files/2023-03/Pulp_and_Paper_Guidance.pdf.
- . 2010. *Combustion Source Database*. Research Triangle Park, N.C.
- . 2021. *Greenhouse Gas Reductions for the US Pulp and Paper Industry*. White Paper WP-21-07. Research Triangle Park, NC: National Council for Air and Stream Improvement, Inc.
- Strickland, Cathy, and John Nyober. 2002. Cogeneration Potential in Canada Phase 2. Report for Natural Resources Canada. MK Jaccards and Associates.

Appendix B: CHP GHG Allocation Approaches for the Pulp and Paper Industry

Introduction

CHP is an energy efficient mode of steam and electricity generation, and the US forest products industry is a leader in the utilization of CHP for industrial energy generation. In 2018, the US forest products industry produced 30% of all CHP power generated by manufacturing industries: 38,663 million kWh total, 5,372 million kWh of which was sold to the electrical grid¹².

Since CHP systems generate steam and electricity simultaneously or sequentially, allocation approaches have been developed to allocate the GHG emissions derived from the combustion of fuels to the multiple products (steam and electricity). Overviews on CHP allocation approaches are reviewed and developed in several publications (Nyober and Groves 2012; Strickland and Nyober 2002; Strickland Nyober 2004; Phylipsen et al. 1998; Rosen 2008; WRI/WBCSD 2006). Within this white paper, CHP GHG allocation approaches are summarized, and allocation approaches are applied to characteristic CHP energy generation in the US pulp and paper sector to determine typical GHG allocation factors for steam and electricity. Properties of characteristic CHP energy generation for the US pulp and paper sector were developed in a companion NCASI memo “Avoided Greenhouse Gas Emissions from the Use of Combined Heat and Power in the US Pulp and Paper Industry.”

Summary of Approaches

Table B1 shows the variation of fractional allocation amounts by method for the US pulp and paper sector. Figure B1 shows the results of Table B1 in graph form.

Table 16. *Variation of Fractional Allocation Amounts by Method*

Allocation Method	f_E	f_Q
Energy Content	0.13	0.87
Incremental Fuel Consumption (Electricity)	0.21	0.79
Work Potential Method	0.22	0.78
Incremental Fuel Consumption (Steam)	0.24	0.76
Simplified Efficiency Method	0.26	0.74
Economic Value Method	0.50	0.50

¹² US EIA MECS Survey Data. <https://www.eia.gov/consumption/manufacturing/data/2018/>

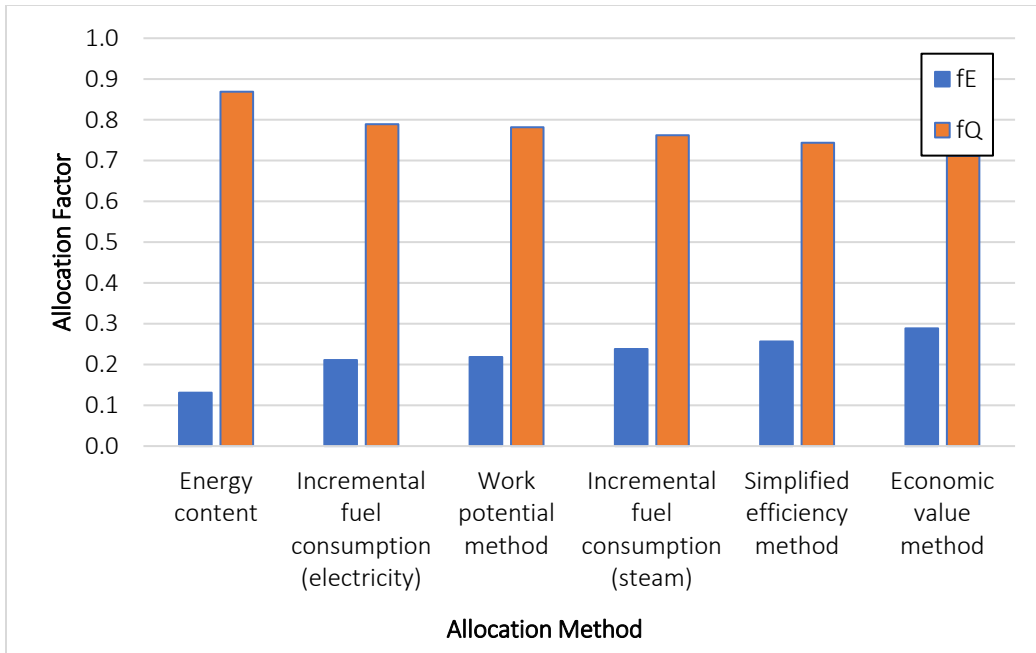

Figure 16. Variation of Fractional Allocation Amounts by Method

Allocation Based on Energy Content of Products

Allocation based on energy content of products allocates GHG emissions according to the quantities of energy contained in each CHP output stream. The advantage of this allocation approach is that it is straightforward and based only on operational outputs. The disadvantage of this approach is that it is based on quantity of energy versus quality of energy.

$$f_E = P / (P + Q)$$

$$f_Q = Q / (P + Q)$$

Where

- f_E : fraction of cogeneration emissions allocated to electricity
- f_Q : fraction of cogeneration emissions allocated to steam
- P : Delivered electricity generation
- Q : Steam output

The Simplified Efficiency Method

The simplified efficiency method allocates GHG emissions according to the amount of fuel energy used to produce each final energy stream. The efficiency method is the preferred method in the WRI/WBCSD (2006) guidance on allocation of GHG emissions from CHP systems.

$$f_E = (P / \epsilon_P) / (P / \epsilon_P + Q / \epsilon_Q)$$

$$f_Q = (Q / \epsilon_Q) / (P / \epsilon_P + Q / \epsilon_Q)$$

Where:

- f_E : fraction of cogeneration emissions allocated to electricity
- f_Q : fraction of cogeneration emissions allocated to steam
- ε_P : efficiency of electricity generation (in the absence of measures of efficiency, typically assume 0.35). The average electrical generation efficiency from coal, nuclear, natural gas, and petroleum fuel sources in the US in 2018 was 0.35. The average electrical generation efficiency from natural gas in the US in 2018 was 0.44.¹³
- ε_Q : efficiency of steam generation (in the absence of measures of efficiency, typically assume 0.8). The steam generation efficiency of 0.8 is typical of a natural gas fired power boiler. Thermal efficiencies of other fuels used in the pulp and paper industry are provided in Table B2.
- P : delivered electricity generation
- Q : steam output

Table B2 shows typical thermal efficiencies for boilers firing different fuels. The efficiencies listed in Table B2 can be used for ε_Q in the simplified efficiency method in the absence of site-specific data.

Table 17. Literature with Published Thermal Efficiencies for Fuel Type Common in the Pulp and Paper Sector

Fuel	Efficiency	Reference
Spent Liquor Solids	61 ^a	Adams (1997)
Spent Liquor Solids	68-69	AGRA (1998)
Hogged Fuel	67	AGRA (1998)
Natural Gas	83	AGRA (1998)
Oil	87	AGRA (1998)
Sludge	65	AGRA (1998)
Spent Liquor Solids and Biomass	64 ^b	Francis (2006)
Coal	85, 75 ^c	CBIO (2003)
Oil	80, 72 ^c	CBIO (2003)
Gas	75, 70 ^c	CBIO (2003)
Biomass	70, 60 ^c	CBIO (2003)

^a Includes soot-blowing 3.4% and boiler blowdown 0.85%.

^b Canadian average.

^c Second number is low load efficiency, numbers are for relatively new units at the time of publication (2003).

¹³ US EIA, Form EIA-923, "Power Plant Operations Report," and predecessor form(s) including US EIA, Form EIA-906, "Power Plant Report;" and Form EIA-920, "Combined Heat and Power Plant Report;" Form EIA-860, "Annual Electric Generator Report."

Work Potential Method

The work potential method allocates GHG emissions based on the useful work that can be performed by the heat and electric power.

$$f_E = W_P / (W_P + W_Q)$$

$$f_Q = W_Q / (W_P + W_Q)$$

It is typically assumed the the conversion efficiency of electrical energy to mechanical work is 1 (100%).

$$W_P = P$$

For thermal—e.g., steam—to mechanical work conversion, Carnot’s theorem states that no engine operating between two heat reservoirs can be more efficient than a Carnot engine operating between the same reservoirs.

$$\eta_T = \frac{W_Q}{Q} = 1 - \frac{T_C}{T_H}$$

Where:

- η_T : the maximum efficiency or Carnot efficiency
- W_P : the work potential by the system from electricity
- W_Q : the work potential by the system from heat
- Q : heat into the system
- T_C : absolute temperature of the cold reservoir
- T_H : absolute temperature of the hot reservoir

Applying Carnot’s theorem, the heat work potential becomes:

$$W_Q = Q\eta_T = Q(1 - T_C/T_H)$$

Superheated steam temeprature trends for the pulp and paper industry have increased over time (NCASI 2019). The choice of cold temperature reservoir influences the Carnot efficiency used in the work potential method. Table B3 shows efficiencies for various superheated steam temperatures, assuming the cold reservoir temperature is a typical return condensate temperature of 95°C.

Table 18. Carnot Efficiencies for the Work Potential Method

Superheated Steam Temperature (K)	η_T
723	0.49
773	0.52
798	0.54

The allocation fractions can be given in terms of the steam and electricity energy amounts and the temperatures of the hot and cold reservoir:

$$f_E = P / (P + Q(1 - T_C/T_H))$$

$$f_Q = Q(1 - T_C/T_H) / (P + Q(1 - T_C/T_H))$$

Or in terms of the Carnot efficiency:

$$f_E = P / (P + Q\eta_T)$$

$$f_Q = Q\eta_T / (P + Q\eta_T)$$

Allocation Based on Economic Value of Products

The economic approach allocates GHG emissions based on the economic value of the electricity and steam produced:

$$f_E = \$_P P / (\$_P P + \$_Q Q)$$

$$f_Q = \$_Q Q / (\$_P P + \$_Q Q)$$

In terms of the ratio of $\$_P/\$_Q$:

$$f_E = P / (P + Q(\$_P/\$_Q))$$

$$f_Q = Q / (P \cdot (\$_P/\$_Q) + Q)$$

Average industrial electricity costs, $\$_P$, can be found in EIA's Electric Power Monthly¹⁴. Average steam costs may be calculated using natural gas as the fuel for steam generation. Natural gas prices may be taken from Henry Hub natural gas prices¹⁵, and natural gas boiler thermal efficiencies are given in Table B2.

Allocation Based on Incremental Fuel Consumption for Electrical Production

The allocation approach based on incremental fuel consumption for electrical production considers steam the primary product and electricity as a secondary product. In this approach, fuel use associated with steam generation is calculated based on a stand-alone steam generation device, i.e., a reference boiler. The fuel use attributed to electricity is calculated as the difference between CHP fuel use and the fuel use calculated from the reference boiler.

$$F_Q = Q / \varepsilon_Q$$

$$F_E = F - F_Q$$

$$f_Q = Q / (F \cdot \varepsilon_Q)$$

$$f_E = 1 - f_Q$$

¹⁴ US EIA. Electric Power Monthly: Table 5.6.A. Average Price of Electricity to Ultimate Customers by End-Use Sector. https://www.eia.gov/electricity/monthly/epm_table_grapher.php?t=epmt_5_6_a

¹⁵ US EIA. Natural Gas: Henry Hub Natural Gas Spot Price. <https://www.eia.gov/dnav/ng/hist/rngwhhdm.htm>

Where:

- f_E : fraction of cogeneration emissions allocated to electricity
- f_Q : fraction of cogeneration emissions allocated to steam
- ε_P : efficiency of electricity generation (in the absence of measures of efficiency, typically assume 0.35). The average electrical generation efficiency from coal, nuclear, natural gas, and petroleum fuel sources in the US in 2018 was 0.35. The average electrical generation efficiency from natural gas in the US in 2018 was 0.44.¹⁶
- ε_Q : efficiency of steam generation (in the absence of measures of efficiency, typically assume 0.8). The steam generation efficiency of 0.8 is typical of a natural gas fired power boiler. Thermal efficiencies of other fuels used in the pulp and paper industry are provided in Table B2.
- P : delivered electricity generation
- Q : steam output
- F : fuel input to the cogeneration system
- F_E : fuel use attributed to electricity generation
- F_Q : fuel use attributed to steam generation

Allocation Based on Incremental Fuel Consumption for Steam Production

The allocation approach based on incremental fuel consumption for steam production considers electricity the primary product and steam generation a secondary product. In this approach, fuel use associated with electricity generation is calculated based on a stand-alone electricity generation device, i.e., a reference power plant. The fuel use attributed to steam is calculated as the difference between CHP fuel use and the fuel use calculated from the reference power plant.

$$F_P = P / \varepsilon_P$$

$$F_Q = F - F_P$$

$$f_E = P / (F \cdot \varepsilon_P)$$

$$f_Q = 1 - f_P$$

Where:

- f_E : fraction of cogeneration emissions allocated to electricity
- f_Q : fraction of cogeneration emissions allocated to steam

¹⁶ US EIA, Form EIA-923, "Power Plant Operations Report," and predecessor form(s) including US EIA, Form EIA-906, "Power Plant Report;" and Form EIA-920, "Combined Heat and Power Plant Report;" Form EIA-860, "Annual Electric Generator Report."

- ε_P : efficiency of electricity generation (in the absence of measures of efficiency, typically assume 0.35). The average electrical generation efficiency from coal, nuclear, natural gas, and petroleum fuel sources in the US in 2018 was 0.35. The average electrical generation efficiency from natural gas in the US in 2018 was 0.44.¹⁷
- ε_Q : efficiency of steam generation (in the absence of measures of efficiency, typically assume 0.8). The steam generation efficiency of 0.8 is typical of a natural gas fired power boiler. Thermal efficiencies of other fuels used in the pulp and paper industry are provided in Table B2.
- P : delivered electricity generation
- Q : steam output
- F : fuel input to the cogeneration system
- F_E : fuel use attributed to electricity generation
- F_Q : fuel use attributed to steam generation

¹⁷ US EIA, Form EIA-923, "Power Plant Operations Report," and predecessor form(s) including US EIA, Form EIA-906, "Power Plant Report;" and Form EIA-920, "Combined Heat and Power Plant Report;" Form EIA-860, "Annual Electric Generator Report."

Appendix B References

- Adams, Terry N., William James Frederick, Thomas M. Grace, Mikko Hupa, Kristiina Iisa, Andrew K. Jones, and Honghi Tran. 1997. *Kraft Recovery Boilers*. American Forest & Paper Association Atlanta, GA: Tappi Press.
- AGRA Simons and Pulp and Paper Technical Association of Canada. 1998. *A Guide to Energy Savings Opportunities in the Kraft Pulp Industry*. AGRA Simons Limited: Vancouver, BC; Pulp and Paper Technical Association of Canada: Brossard, QC.
- CIBO (Council of Industrial Boiler Owners). 2003. Energy Efficiency and Industrial Boiler Efficiency: An Industry Perspective. <https://invenoinc.com/wp-content/uploads/2017/05/CIBO-Steam-System-Efficiency-and-Boilers.pdf>.
- Francis, Bill, Michael Towers, and Tom Browne. 2006. "Benchmarking Energy Use in Pulp and Paper Operations". 92nd Pulp and Paper Technical Association of Canada Annual Meeting: Montréal, QC.
- NCASI (National Council for Air and Stream Improvement, Inc.). 2019. General Trends in Pulp and Paper Boiler Development. Technical Memorandum.
- Nyober, John, and Steve Groves. 2008. A Review of Existing Cogeneration Facilities in Canada. Report by Canadian Industrial Energy End-Use Data and Analysis Center (CIEEDAC). Burnaby, BC: Simon Fraser University.
- Nyober, John, and Steve Groves, S. 2012. A Review of Existing Cogeneration Facilities in Canada. Report by Canadian Industrial Energy End-Use Data and Analysis Center (CIEEDAC). Burnaby, BC: Simon Fraser University.
- Strickland, Cathy, and John Nyober. 2002. Co-generation Potential in Canada Phase 2. Report for Natural Resources Canada. MK Jaccards and Associates.
- Strickland, Cathy, and John Nyober. 2004. A Review of Existing Cogeneration Facilities in Canada. Report by Canadian Industrial Energy End-Use Data and Analysis Center (CIEEDAC). Burnaby, BC: Simon Fraser University.
- Philipsen, G. J. M., Kornelis Blok, Ernst Worrell. 1998. *Handbook on International Comparisons of Energy Efficiency in the Manufacturing Industry*. Netherlands: Department of Science, Technology and Society, Utrecht University.
- Rosen, Marc A. 2008. Allocating Carbon Dioxide Emission from Cogeneration Systems: Descriptions of Selected Output-based Methods. *Journal of Cleaner Production*. 16, no. 2: 171–177. <https://doi.org/10.1016/j.jclepro.2006.08.025>.
- World Resources Institute (WRI) / World Business Council for Sustainable Development (WBCSD). 2006. Allocation of GHG Emissions from a Combined Heat and Power (CHP) Plant: Guide to Calculation Worksheets (September 2006) v1.0: A WRI/WBCSD GHG Protocol Initiative Calculation Tool. https://ghgprotocol.org/sites/default/files/ghgp/CHP_guidance_v1.0.pdf